

1) TOOL TYPE - GERÄTETYP - DESCRIZIONE MACCHINA - TYPE D'OUTIL - TIPO DE MAQUINA

cod. R31855

HEAD CN15W-PS65 SCR

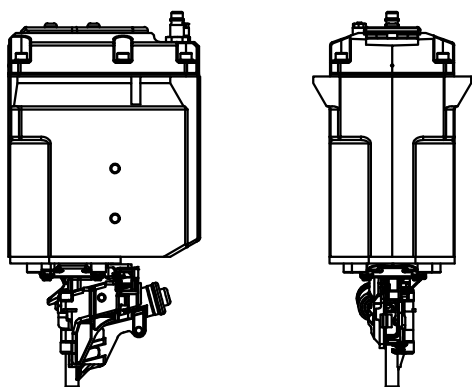

2) TOOL CHARACTERISTICS  
 SPEZIFIKATION DES GERÄTES  
 CARATTERISTICHE TECNICHE  
 CARACTÉRISTIQUES DE L'OUTIL  
 CARACTERÍSTICAS DE LA MAQUINA

HEIGHT - HAUTEUR HOEHE - ALTURA ALTEZZA	WIDTH - LARGEUR BREITE - ANCHURA LARGHEZZA	LENGTH - LONGUEUR LAENGE - LONGITUD LUNGHEZZA	WEIGHT - POIDS GEWICHT - PESO PESO
in. 15.35 mm. 390	in. 10.43 mm. 265	in. 20.47 mm. 520	lbs. ----- kg. -----
MIN-MAX WORKING PRESSURE MIN-MAX ARBEITSDRUCK MIN-MAX PRESSIONE DI ESERCIZIO MIN-MAX PRESSION DE TRAVAIL MIN-MAX PRESION DE TRABAJO		70 / 120 psi 5 / 8 BAR	
AIR CONSUMPTION PER CYCLE LUFTVERBRAUCH PRO NAGELUNG CONSUMO ARIA PER COLPO CONSUMATION DE L'AIRE PAR COUP CONSUMO DE AIRE CADA DISPARO		PERFORMANCES AT 90 psi (0.62 MPa) PRESTAZIONI A 6.2 BAR (0.62 MPa) 0.145 SCF 4.10 L.	
LUBRICANT SCHMIEROEL LUBRIFICANTE LUBRIFIANT LUBRIFICANTE		AEROSPACE LUBRICANTS TRIBOLUBE 12	

* ACTUATION SYSTEM * AUSLÖSEART * ATTUAZIONE * MISE EN ŒUVRE * ACTUACIÓN	0	* LOADING * LADEN * CARICAM. * CHARGER * CARGA	BOTTOM LOADING SIDE LOADING TOP LOADING COIL OTHER
--	---	--	--

\* SEE INSTRUCTION MANUAL - SIEHE BETRIEBSANLEITUNG  
 - VEDI MANUALE - VOIR MODE D'EMPLOI - VER EL MANUAL

NOISE CHARACTERISTICS GERÄUSCH - EMISSION DATEN CARATTERISTICHE RUMOROSITA' CARACTÉRISTIQUES ACOUSTIQUE CARACTERÍSTICAS DE RUIDO	EN 12549+A1:2008 EN ISO 4871:2009
$L_{WA,1s}$ : 98.38 dB(A) - $K_{WA,1s}$ , 2.5	
$L_{pA,1s}$ : 93.00 dB(A) - $K_{pA,1s}$ , 2.5	

VIBRATION VALUE VIBRATIONSWERT VALORE DI VIBRAZIONE VALEUR DE VIBRATION VALOR DE VIBRACIÓN	UNI ISO/TS 8662-11
--	-----------------------

3) FASTENER DATA  
 ANGABEN ZU DEN BEFESTIGUNGSMITTELN  
 CARATTERISTICHE TECNICHE FISSAGGI  
 DONNÉES DES PROJECTILES  
 DATOS DE CLAVOS

SCRAIL®					
		FINE		COARSE	
		MIN	MAX	MIN	MAX
A-B) WIRE SCHAFT FILO ALAMBRE TIGE	WIRE mm in	.098 - .138	2.5 - 3.5	.098 - .134	2.5 - 3.4
	PLASTIC mm in	.098 - .138	2.5 - 3.5	.098 - .134	2.5 - 3.4
C) HEAD KOPF TESTA TETE CABEZA		STAR / TORX VERSA PHILIPS POZI		STAR / TORX VERSA PHILIPS POZI	
L) LENGTH LAENGE LUNGHEZZA LONGEUR LONGITUD	WIRE mm in PLASTIC mm in	1 1/2' - 2 1/2' 38 - 65		1 1/2' - 2 1/2' 38 - 65	
MAGAZINE CAPACITY MAGAZIN CAPAZITÄT CAPACITA' CARICATORE CAPACITE' CHARGEUR CAPACIDAD CARGADOR					

NAIL					
				SHANK	
				- SMOOTH - RING - SCREW - KNURLED	
		WIRE		PLASTIC	
		MIN	MAX	MIN	MAX
A) WIRE - SCHAFT FILO - ALAMBRE TIGE	in mm	.091 - .110	2.3 - 2.8	.091 - .110	2.3 - 2.8
B) PITCH - TEILUNG PASSO - PAS PASO	in mm	.275 - .314	7.0 - 8.0	.295	7.5
C) HEAD - KOPF TESTA - TETE CÂBEZA	in mm	.197 - .275	5.0 - 7.0	.197 - .275	5.0 - 7.0
L) LENGTH - LAENGE LUNGH. - LONGEUR LONGITUD	in mm	1' - 2 1/2'		1 1/4' - 2 1/2'	
MAGAZINE CAPACITY MAGAZIN CAPAZITÄT CAPACITA' CARICATORE CAPACITE' CHARGEUR CAPACIDAD CARGADOR					